

# Airwash Whisper Air Filtration Systems



## Three-Stage Filtration

**Stage 1:** Washable Foam pre-filter  
Removes large particulates.

**Stage 2:** HEPA filter  
99.97% efficient @ 0.3 microns. Removes dust, pollen, bacteria, animal dander, attached viruses, cigarette smoke, radon daughters and more.

**Stage 3:** V.O.C. filter  
Removes hazardous chemicals that may off-gas from cleaners, paints, solvents, carpets, furniture and other items containing synthetic materials.

## Easy-to-Change Filters

Easily removable for quick filter changes. Ask about filter options.

## Metal Cabinets

Provide greater protection of filters and internal components and do not emit toxins.

## Highly-Efficient Motor/Fan

Low electrical consumption when continuously run over a long period of time.



### How the Airwash™ works

Amaircare central systems operate on a by-pass system. A portion of the home's return air is routed through the air filtration system before it reaches the furnace or air handling system. This rerouted air is cleaned and fed back into the home's air supply via the furnace. By continuously cleaning the air significant reduction in pollution results.

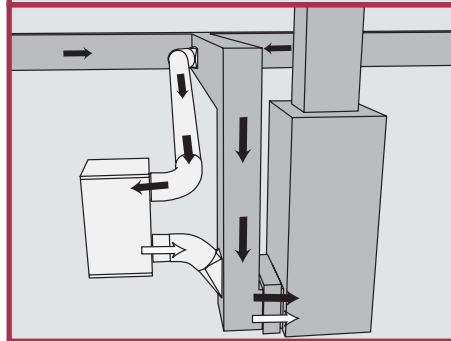

## Specifications (All Models)

### CLASSIFICATION

- Central HEPA (High Efficiency Particulate Air) 100% Sealed Air Cleaning Device
- C.S.A. approved

**MATERIALS:** 24 gauge cold rolled steel

**FINISH:** Powder coated baked enamel

**COLOR:** Sandtext Granite

### INTAKE (Section)

Steel enclosure surrounding a three-stage filter assembly.

### OUTFLOW (Section)

Encloses motor/fan.

### MOTOR/FAN

- Thermally protected Class "B" insulated motor
- Designed for continuous operation.
- Run tested for 50,000 hours
- Service: 120 Volt, 60 Hz or 230 Volt, 50/60 Hz

**CONTROL:** on/off control panel

### FILTER LIFE

**Stage 1:** Foam Filter: Reusable

**Stage 2:** HEPA. Filter: 2-5 years

**Stage 3:** Carbon Filter: 6-12 months

## Model AWW-350



### DIMENSIONS:

14.5" W 27.25"H

**INTAKE:** 8" Duct Collar

**OUTAKE:** 6" Duct Collar

**WEIGHT:** 30 lbs.

**AIR FLOW (C.F.M.):** 350

**POWER USAGE:** 125 Watts

## Model AWW-675



### DIMENSIONS:

14.5" W 27.25"H

**INTAKE:** 10" Duct Collar

**OUTAKE:** 8" Duct Collar

**WEIGHT:** 33 lbs.

**AIR FLOW (C.F.M.):** 675

**POWER USAGE:** 225 Watts

- 100% AIR SEAL** (TOP AND BOTTOM)
- INTAKE COLLAR**
- FOAM PRE-FILTER (STAGE 1)**
- PROTECTIVE SCREEN FOR HEPA FILTER**
- HEPA FILTER (STAGE 2)**
  - REMOVES 99.97% OF PARTICULATES FROM 0.3 MICRONS
  - 100 SQ. FT SURFACE AREA
  - LASTS UP TO 5 YEARS
- V.O.C. FILTER (STAGE 3)**
- POWERFUL, EFFICIENT MOTOR/FAN**
  - C.S.A. AND N.T.R.L. (U.L.) APPROVED
- CONTROL PANEL**
- OUTFLOW COLLAR**
- VOC Canister (optional)**

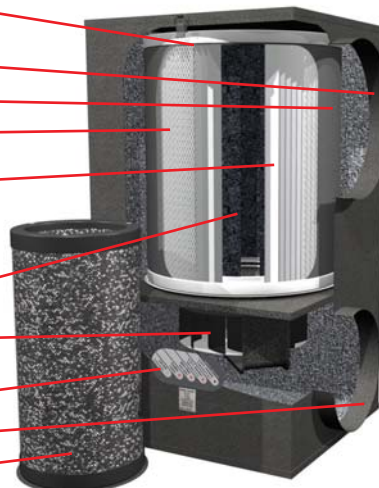

Amaircare products available at:

